

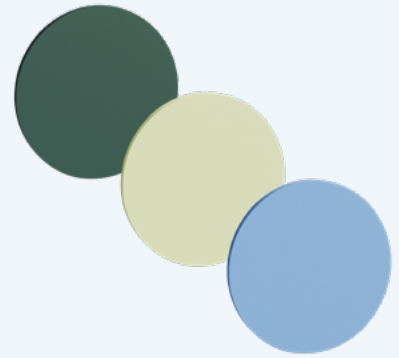

Installation Manual **ARCHADIA Clouds**



Ceiling clouds are a highly flexible and durable solution that helps absorb sound and provide better acoustics when used alone or with other Primacoustic sound control products. Whether strategically placed to control sound in problem areas or cover large portions or an entire ceiling, clouds can conceal unsightly infrastructure and make a visual statement, enhancing aesthetics when deployed in patterns, colors, and textures that match the environment. Their popularity is based on their ability to absorb sound, cut down on reverberation, and enhance the look and feel of any space, sonically and visually, in any space, making them the ideal solution for achieving superior acoustic performance and high-value aesthetics in many applications and spaces, from auditoriums to restaurants, to house of worship and performing arts venues.

Installation Guidelines

DENSITY

The number of clouds in a given area will determine the rate of sound absorption. This can vary depending on room size and noise levels.

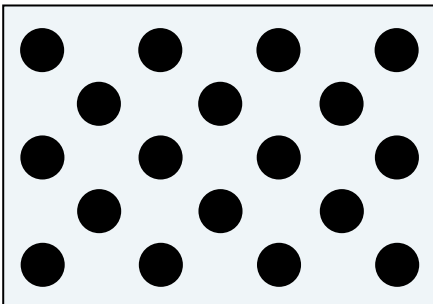
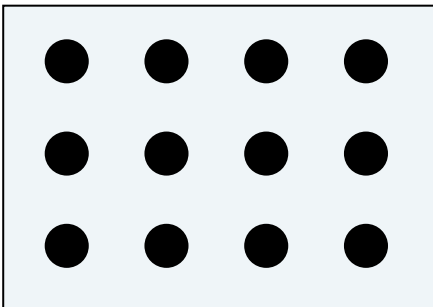

LOCATION

Spread evenly for general sound control, or concentrate over noisy areas to absorb sound before it can reflect.

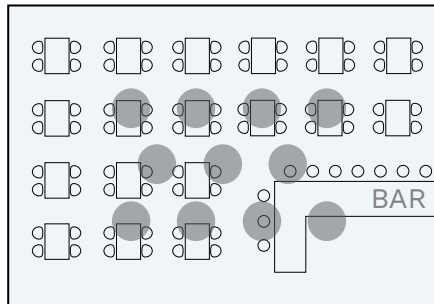
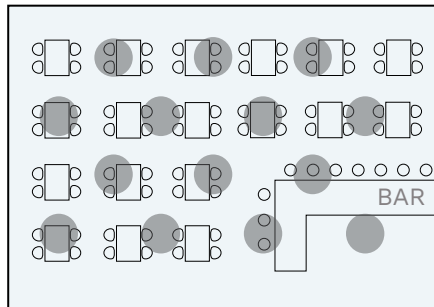

SUSPENSION HEIGHT

Leave a minimum 3" (76mm) of air space between the panel and ceiling, up to a maximum of 75" (150cm)

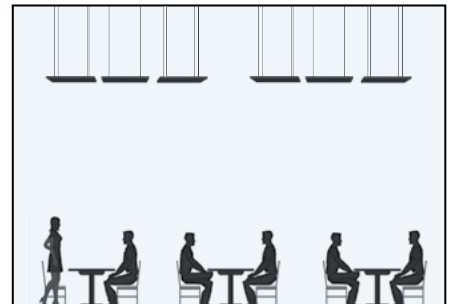
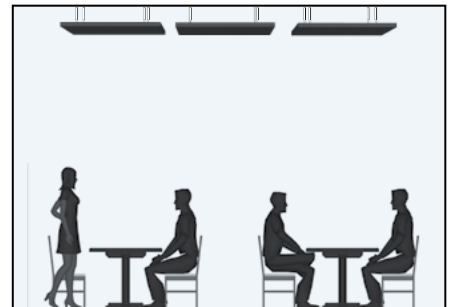

Installation

Tools & materials required:

- Measuring Tape
- Screwdriver
- Ladder/Scaffolding
- Hammer
- Drill 3/32" or 1/4" bit
- Wire Clippers

Please Note: We recommend using the official Primacoustic hardware described in this guide to suspend your clouds. When using other hardware, many of the same principles will apply.

1. Panel Anchor Locations

Firstly, measure and mark the backside of each panel at the points where anchors will need to be placed. The exact number and position of anchors, will depend on the size of your panels. Please also refer to the recommended maximum weight limit of your chosen hardware.

- Anchors should be placed a minimum of 4" (101mm) in from the panels edge.
- Circular panels work best with 3 anchor points. This will make it easier to level the panels later.
- Otherwise, 4 anchors, one at each corner is a good starting point.
- For larger panels, extra anchor points may be required, to distribute the panel's weight more evenly and avoid sagging. Add an extra anchor roughly every 3½' (1,067mm).

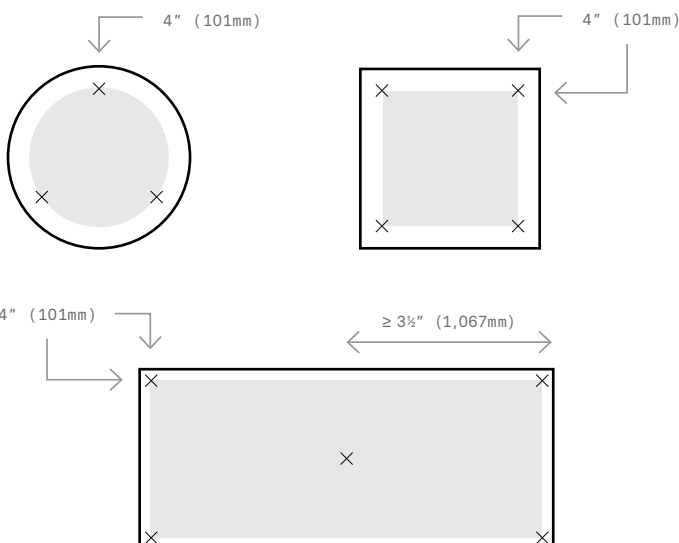

2. Ceiling Anchor Locations

Measure and mark your ceiling for suspension point locations. Ceiling anchors should be spaced to match those marked on the panel in the previous step. Creating a cardboard template may help with this.

Pay close attention to where you want the panel to be situated. This way the panel anchors will be directly below each ceiling mounting point. All cables should hang perfectly straight to create a dead hang.

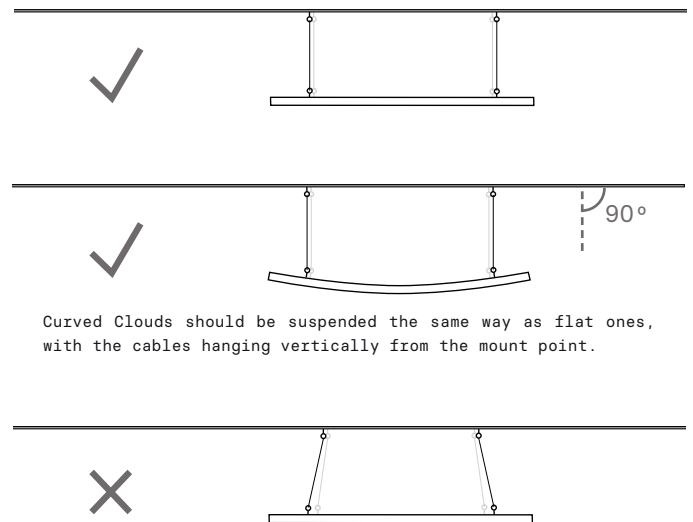

3. Installing Ceiling Anchors

The next steps will vary, depending on the type of ceiling you are suspending your clouds from.

3a. Solid Backed Ceiling

If one or more of your ceiling anchor locations is on a solid backing, such as a joist, no butterfly anchors are required. Simply use a 1/8" (3.2mm) drill bit to make a pilot hole and screw an eye-screw in directly.

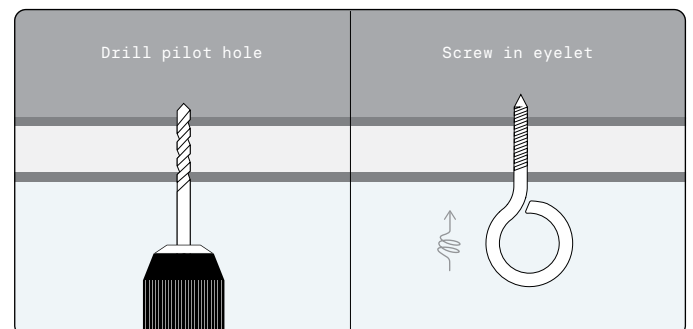

3b. Hollow Backed Ceiling

If the backing above your ceiling is hollow, use a 5/16" (7.9mm) drill bit to make a hole for a butterfly anchor and follow the steps below. Repeat the anchor and eye-screw installation until all your suspension points are ready.

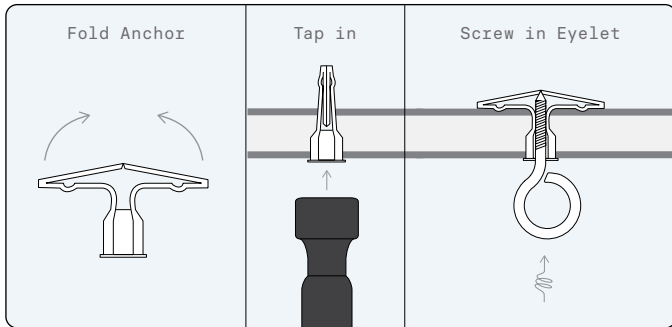

4. Twist In The Helix Anchor
With the panel face down, push and twist a Helix panel anchor into the panel until it breaks through the micromesh and is flush with the panel. Repeat for the other anchors.

5. Attach The Ceiling Eyelets

Remove the hook from the SlipNot cable by pushing in the center pin. Feed the wire through the ceiling eyelet, then through the looped end of the wire. Reattach the hook by pushing the wire through the center pin.

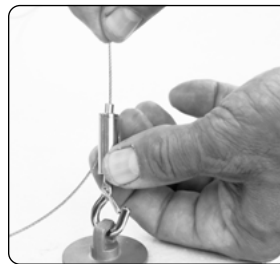

6. Attach The Panel
Clip the SlipNot hook through the opening on the Helix anchor. Pull the cable to adjust the height.

7. Suspend And Level

With the panel suspended, you can fine tune the lengths of the SlipNot by pressing the center pin to release the cable. Level the panel and set the spacing between ceiling and the panel. For the best acoustic performance maintain a minimum of 3 inches (76mm) spacing.

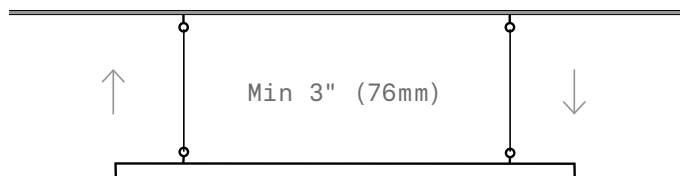

Limited Warranty

Please inspect products immediately after receiving your purchase. Primacoustic acoustic products are guaranteed to be free of manufacturing defects for a period of 3 years after purchase. In the unlikely event that a defect is uncovered, please call 604-942-1001 to obtain a RA number (Return Authorization number) from Primacoustic before the 3 year warranty period expires. Once you have obtained a RA number you must return the product, freight prepaid, within fifteen (15) days after the date the RA number is issued. Please return the product in the original packaging (or another, affording an equal degree of protection) with all of the following: (1) RA number clearly marked on the returned package; (2) a receipt or bill of sale showing proof of purchase from an authorized seller; plus (3) a letter describing the defect. Please include your name, address, telephone number and the applicable RA number. You are solely responsible for all shipping and insurance costs for returning the product to Primacoustic, and you will not be reimbursed or compensated for any loss or damage incurred during return shipping. Primacoustic will at its sole discretion repair or replace the product. Should the product no longer be available, Primacoustic reserves the right to exchange this with a product of similar performance and value. Due to different dye lots, Primacoustic cannot guarantee exact color match. This Warranty shall solely extend to the original owner and is limited to manufacturing defects and excludes damage due to improper installation, freight handling, wear and tear, abuse, misuse, misapplication, color fading or deterioration due to prolonged exposure to ultra violet light, smoke, humidity or other environmental factors. It is understood that the use and suitability of the product is entirely the responsibility of the buyer or specifying engineer and as such, these parties agree to hold Primacoustic, or its associated company, and/or officers, harmless from any responsibility whatsoever other than what is clearly outlined in this warranty.